

MAGIC

19

19

PIDGIN

19

19

19

MAGIC

01

LETTER TO A MAGICIAN

Leslie van Duzer

08

HIDDEN ARCHITECTURE:
SUPERSTUDIO'S MAGIC BOX

Sebastiano Fabbrini

24

SLEIGHT OF HAND:
ON THE DURATION OF THE SCAN

Brendan Shea

28

TEASING OUT THE MAGIC OF (GOTHIC)
ARCHITECTURE

Eeva-Liisa Pelkonen

40

MODERN MIRAGES AND MONSTERS,
ARCHITECTURE IN JAPAN 1790/1892

Matthew Mullane

52

STREET LIGHT DISCO

Office Feuerman

56

MAGIC ARCHITECTURE (EXCERPTS)

Frederick Kiesler

Preface by Spyros Papapetros

82

FLOATING SHADOWS

Nat Chard

96

OBJECTS WITH ARCHITECTURAL QUALITIES

Andrew Kovacs

104

DATUM EXPLORER:
MULTI-PLATFORM REALITIES

UniversalAssemblyUnit

112

ROCKS, WORDS, AND THE MAGICALLY REAL

Adam Fure

121

TWO-FACE

Laurel Broughton

131

BEHIND THE CURTAIN

Victor Enrich

140

MAGIC IS IN THE SETUP

Emily Abruzzo & Gerald Bodziak

150

ROACH SCAN

Ben Denzer

154

SITE SURVEYOR

Jon Piasecki

160

MAYASABHA

Swarnabh Ghosh

CONTENTS

166

VĀSTU: A RENAISSANCE IN SPACE.
COMING WEST THROUGH THE EAST.

Daria Ricchi

173

ALONG THE FRONTIER OF RESOLUTIONS

Erin & Ian Besler

182

FLUID PLEASURE

On the Road

192

MADE IN CHINA:
THE RISE OF THE MIMETIC SUBURB

Leen Katrib

205

MAGICAL DINING MODERN CUISINE

Jonathan Crisman

214

EVERYDAY MAGICAL URBANISM

Thomas Mical

226

DO YOU KNOW ANYONE
WHO MIGHT BE INTERESTED?

David Eskenazi

Sebastiano
HIDDEN
ARCHITECTURE:
SUPERSTUDIO'S
MAGIC BOX
Fabbrini



Superstudio: Magic Box. *Design Quarterly* 78/79 (1970).

“We propose a HIDDEN ARCHITECTURE as conceptual architecture: architecture which is only an image of itself and of our instrumentalizable muteness.”¹

In the summer of 1970, Superstudio was invited to submit a project for a special issue of *Design Quarterly* dedicated to conceptual architecture.² In opposition to “all the works of architecture that were designed to be seen and nobody ever saw,” Superstudio proposed an architecture designed to remain hidden.³ The submission was a sequence of photographs documenting the operation of hiding an architectural project in hermetically sealed covers. Three copies of the project drawings were folded into A4 size and sealed in a polyethylene envelope, which was wrapped in a polyester and aluminum foil cover and then placed into a box made of 1.5 mm thick zinc sheeting measuring 250x350x75 mm. The original drawings were burned into ashes. The box was then labelled with the inscription HIDDEN ARCHITECTURE + SUPERSTUDIO. Less than one year after the death of Mies van der Rohe, Superstudio’s happening aimed to reinterpret the theme of the box—a formal emblem of Modern architecture—as a machine that encloses and ultimately devours architecture. Reading the decline of the Modern movement as the beginning of the “joyous death of architecture,” Superstudio was striving to redefine the role of the architect in this new era.⁴ As the major language of action, synthesis, and spectacle quickly faded, a minor language based on conceptual thinking, analysis, and self-questioning began to emerge. *Hidden Architecture* sought to radicalize this tension within the discipline.

What did hiding mean for Superstudio? First, to hide means to put something out of sight. In disengaging the architectural project from the visual realm, Superstudio’s happening presented the design process as a conceptual one: “hide the project and tell the world why it is hidden.”⁵

To hide also means to conceal something for shelter or protection. Even though the group argued that the project should remain hidden forever, the box seemed to perform as an architectural stasis chamber—the coffin-shaped device often used in sci-fi films to temporarily preserve the life of terminally ill patients until they can be nursed back to health in a more hospitable space and time. But to hide also means to keep a secret.⁶ In one of his numerous notebooks, Adolfo Natalini wrote: “this project will remain a secret—we all give our word of honour that we will never reveal its content.”⁷ Evoking the secrecy of the builders’ guilds of medieval Florence, the group wanted to contrast the “fictitious communication of most architectural magazines” with the concealment of the project’s content.⁸

However, it would be naïve to read *Hidden Architecture* as an anti-architectural statement. The drawings were obfuscated of course, but the article was published in an important journal that exposed the work to a large international audience. The project could not be seen, but the publication mobilized a rich visual apparatus of photographs. Moreover, Superstudio went to great lengths to promote and advertise this publication.⁹ In other words, the muteness of the hidden project was at variance with the happening and its mediation. In fact, *Hidden Architecture* did not suggest the negation of design, but rather a shift of focus from the design of the architectural project to the design of the processes of creation and communication of the architectural happening.

This did not mean that no attention was paid to the project itself. On the contrary, Natalini stressed that the project hidden in the box was “a great project, an important project, a beautiful project—a project resolved in all its details and designed with even more care than usual.”¹⁰ The emphasis on the quality of the hidden project—which could not be verified

since the box was sealed—was a theatrical exaggeration aimed to show that, regardless of the content of the drawings, what really mattered was the “routine of labour” behind the project.¹¹ The decision to burn the original drawings and to use a series of copies might be explained by exploring this tension between the architectural project and the happening. The original drawings were the only documents of the architectural project, whereas the copies belonged to a different design process—the routine of labour of the happening. By burning the originals, Superstudio erased the only material traces of the hidden project, thus highlighting an irreversible absence.

In light of these considerations, two design processes supplementing the design of the project hidden in the box appear to have been engineered to operate on different levels in the *Hidden Architecture* hap-

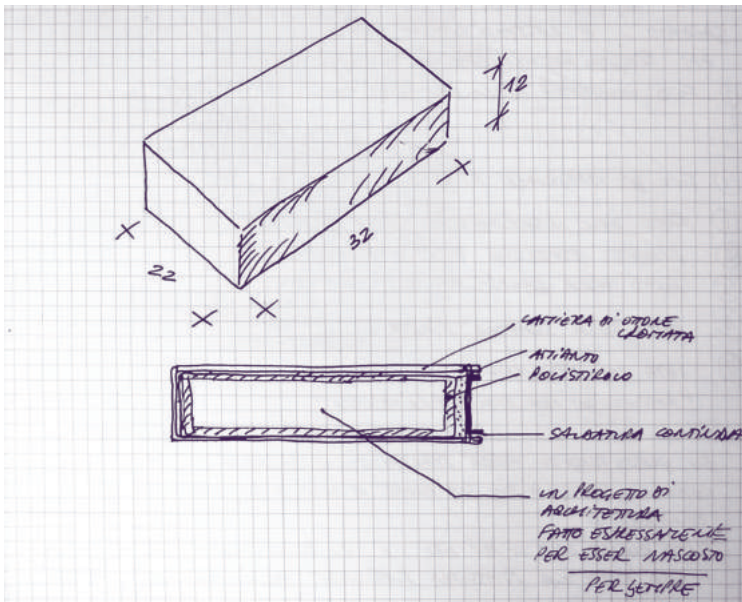

FIGURE 1

Adolfo Natalini: section and axonometric sketch of the box.
Courtesy of Adolfo Natalini.

pening. The first is the design of the hiding happening itself. Every single detail of this process was designed with extreme precision—from the selection of pens and pencils to the folding of the drawing sheets, from the materials of the envelopes to the dimensions of the box (specified to the millimeter). As demonstrated by an axonometric drawing and a section sketched in Natalini’s notebook, particular attention was paid to the design of the box.¹² The architectural quality of this object is quite evident: a person not familiar with the project could easily mistake these sketches for preliminary drawings of a building. The drawings specify not only the dimensions of the box, but also its material composition: an internal layer of foam, an intermediate layer of asbestos, and an external chrome plated brass sheeting (brass was replaced with zinc in the final box). From the seemingly purposeless foam insulation layer to the external cladding, every component of the section evokes an actual building. The box was not only the container of a hidden architectural project: it was also an architectural project in itself—a project for a hiding architecture. This architecture was not conceived as a Modernist machine for living in, but rather as a machine for hiding in.

The design of the overall happening, however, must be positioned in relation to another design process: the design of the publication of the happening—that is, the design of the presentation and communication of *Hidden Architecture* to the world.¹³ Photography was clearly the most important medium in Superstudio’s publication. The photographic sequence that documented the “hiding ritual” was staged in the workshop of the Florentine blacksmith Silvano Valleri: the journey of the box from the neutral surface of Superstudio’s office table to the rough surface of Valleri’s wooden desk underscored the disjunction between the manual and the conceptual aspects of the project.¹⁴ In these images, Natalini



Firenze, 25th of July 1970.

On the 25th of July 1970, Arch. Adolfo Natalini, Arch. Cristiano Toraldo di Francia, Mr. Roberto Magris, Arch. Giampiero Frassinelli, Arch. Alessandro Magris, partners in the SUPERSTUDIO, to me all known, came before me personally, and in my presence sealed an envelope containing the only three existing copies of a project designed by themselves, after having burned in my presence the original drawings. The above mentioned sealed copies, placed in protective coverings, were then enclosed in a metal box which was soldered in my presence by Mr. Silvano Valleri in his workshop in Florence.

Dott. Proc. Andrea Orsi Batsaglioni



14

FIGURE 2
Lawyer's account. *Design Quarterly* 78/79 (1970).

and his partners presented themselves as the minds behind a “routine of labour” performed by others, their own manual labour (the original drawings) having been burnt to ashes. A lawyer was brought in to oversee the procedure and to certify an authorship bound to the conceptual orchestrations behind the entire happening rather than the original drawings themselves.¹⁵ Every aspect of the happening, from the photographic documentation to the lawyer’s witnessed account, was carefully designed and staged for the article. What allowed for the unfolding of these supplementary, intertwined design processes was nothing other than the absence of the hidden project.

A few notes found in Natalini’s archive reveal that *Hidden Architecture* was part of a larger conceptual framework, a “list of operations” made up of three steps.¹⁶ *Hidden Architecture* was the last part of this project and was preceded by two other operations: the first was called *Subtractions / Substitutions* and the second was called *Topographic Architecture*. Both are described meticulously in Natalini’s notebook, but for unknown reasons were never implemented or published.¹⁷ How were the three operations connected to each other, and why did Superstudio submit only *Hidden Architecture* for publication in *Design Quarterly*? Though they remained unpublished, the first two projects addressed a number of issues that were central to Superstudio’s approach to conceptual architecture and therefore can contribute to a closer reading of *Hidden Architecture* and the broader practice.

The first project, titled *Subtractions / Substitutions*, consisted of a series of photomontages in which major monuments—the leaning tower of Pisa, the cathedral of Milan, and the baptistry of Florence—were subtracted from their postcard-like views. The aim was to “invent a void in a context with a strong historical and formal definition.”¹⁸ The photomontages



FIGURE 3
Superstudio: photographic sequence of the hiding process. *Design Quarterly* 78/79
(1970).

were meant to reconstruct these environments, filling the void created by the subtraction of these monumental architectures with a neutral or grass surface. Though the photomontages were never made, this language of subtraction played an important role in Superstudio's theory and influenced the parallel development of the hiding project. This same language was used by Peter Eisenman in his well-known essay "Notes on Conceptual Architecture," published as the opening article of the issue of *Design Quarterly* discussed here.¹⁹ In Eisenman's article, the text—the monumental product of the writing process—was subtracted from the page: the only inscriptions left on the blank sheet were the footnotes. Emptying the object of its monumental component, both Superstudio and Eisenman focused the viewer's attention on the minor things that surround a monument and define its context. Hence, for example, the subtraction of the leaning tower transformed the dense fabric of buildings (we may call them urban footnotes) surrounding Pisa's piazza into the protagonist of that environment.

Superstudio's interest in monumental architecture—which inspired the *Continuous Monument* project of the same year—was deeply rooted in the preservationist debate that unfolded in Italy in the post-war period.²⁰ One of the main focuses of this debate was the relationship between the city and the monument. The wild speculations of post-war reconstruction, along with the series of natural disasters that threatened the historic centers of Agrigento, Florence, and Venice in the mid-1960s, pushed architects and planners to rethink their approach toward the built environment.²¹ The bombing of several Italian cities during World War II had radicalized the disjunction between monumental architectures and their urban contexts. For example, "How to Miss Historic Sites," an article published in 1944 by the *Air Force Journal*, shows that fighter pilots in the skies of Florence were instructed to bomb everything

18 LUGLIO 1990
SUPERSTUDIO
Piazza Pellegruoso, 1
50124 FIRENZE - Tel. 224067

UNA LISTA DI OPERAZIONI —

① LE SOTTRAZIONI / SOSTITUIZIONI
DA LUOGNI DETURATI, DA CEDERE PASSEGGI DA CARROZINA VIENE
SOTTRATTO IL RICONTRONTO — ES. TORRE DI PISA, QUARTO DI MUGELLI,
BAPTISTERO FIRENZE ECC. VIENE RICOSTRUITA A FOTOFOTONTAGGIO LA
PIAZZA (O SOSTITUITA CON TERRENO EMBOSO O ALTRO) —
IN OGNI FASE SI INVENTA UN VUOTO IN UNA SITUAZIONE
STORICAMENTE E PARTICOLARE DEFINITA —

② ARCHITETTURA TOPOGRAFICA —
OPERAZIONI DI INSERIMENTO ARCHITETTONICO DI RISTORI GEOGRAFICHE —
OPERAZIONI DI GEOGRAFIA COSTRUITA —
ES. QUADRATO PER FIRENZE —
A) UNA PIATTA QUADRATA (COMPOSTA) IN PIAZZA DEL DUOMO —
B) UNA PROPOSTA DI NUOVO QUADRATO INTORNO AL CENTRO CANTINO —
C) QUATTRO AT "VERTICI" SULLE COLLINE

A) 100

B) 100

C) 100

③ DOCUMENTAZIONE FOTOGRAFICA DEL PIANIMENTO DEL QUADRATO —
" "

B) FOTOFOTONTAGGIO
C) FOTO DA OGNI VERTICE PER LOCALIZZARE GLI ALTRI VERTICI —

Al.6. OGNI FASE E' DOCUMENTATA SULLE CARTE TOPOGRAFICHE 1:4.77.

③ ARCHITETTURA NASCOSTA —
L'ARCHITETTURA E' SIGILLATA IN UNA SCATOLA SALDATA E CROCIATA

FIGURE 4

Adolfo Natalini: list of operations. Subtractions / Substitutions, Topographic Architecture, and Hidden Architecture. Courtesy of Adolfo Natalini.

but a restricted group of monuments.²² The same approach had been used in many other European cities: an idiosyncratic form of preservation was taking place.

Before the war, architects such as Camillo Boito and Gustavo Giovannoni, influenced by the theories of Camillo Sitte, had already started to argue for the expansion of preservation's domain from buildings to environments. After the reconstruction, this debate was reactivated by the next generation of architects, including Cesare Brandi and Roberto Pane, who introduced the notion of "environmental preservation." This concept finally entered municipal policies in 1964 with the *Venice Charter* and was reaffirmed a few years later by the *Franceschini Commission* and, more importantly, by the *Italian Preservation Charter*. The latter introduced the principle of *salvaguardia*, the preservation of the "environmental context of the architectural monument."²³ Hence, borrowing Franceschini's words, an abandoned hut was meant to be preserved with the same degree of care as a Palladian villa.

Superstudio was deeply involved in this debate and worked on several projects related to the issue of monumental architecture. Looking at these projects, two main conceptual patterns can be identified. The first pattern was based on the fusion of the city and the architectural monument into a single gigantic object. The monument was expanded to absorb the surrounding urban and rural environment, producing an "architectural model for total urbanization." Influenced by Aldo Rossi's analogy between city and architecture, Superstudio wanted to extend the monumental status of architecture *ad infinitum*, a proposal that encouraged a greater consideration of the monument's environmental context at the same time as it critiqued the "modern cult of monuments."²⁴ The most well-known example of this conceptual model is the *Continuous*

Monument project, but similar patterns can be found in *Topographic Architecture*, the second project in the “list of operations” designed for *Design Quarterly*.²⁵ Presented as an “operation of built geography,” *Topographic Architecture* was a project for a colossal square wall around the city of Florence that transformed a heterogeneous urban fabric overrun with isolated monuments into a homogeneous monumental object.²⁶

The second pattern revolved around the notions of subtraction and erasure. As clearly illustrated in *Subtractions / Substitutions*, the removal of the monument allowed for a greater focus on the minor objects of the city—objects that constitute the fabric of the built environment and that are often overlooked. In a recent essay on Superstudio’s *Salvages of Italian Historic Centers*, Lucia Allais has suggested that the erasure of historic monuments in the group’s photomontages was not an act of violence, but rather a radical form of preservation.²⁷ *Salvages of Italian Historic Centers*, a project influenced by *Subtractions / Substitutions* and published by *IN Magazine* in 1972, proposed a series of radical interventions on historic city centers: flood Florence permanently, bury Rome under a hill of trash, enclose Milan in a cubic cage filled with smog, and other provocations of this nature.²⁸ The goal of these operations, however, was not destruction: instead, the argument was that “buildings are conserved better and longer when they are buried or submerged than when they are exposed to the erosive action of time.”²⁹ For Superstudio, the best way to preserve the Coliseum or Santa Maria del Fiore was to hide them—to subtract them from the image of the city. The quote by archaeologist Amedeo Maiuri chosen for the introduction of the *Salvage of Rome* conveys this idea very clearly: “It is profoundly wrong to extract archaeological treasures from the protection of the earth, which had preserved them for millennia, at least until we have the technology to ensure their conservation.”³⁰ When the conditions for the presence and

preservation of architecture were not being met, Superstudio's response was to subtract architecture from the picture, to bury it under a pile of garbage, or to hide it in a box.

Hiding and subtracting, however, were more than acts of preservation. Behind the subtractions of the tower of Pisa or the cathedral of Milan, there was a project for the "substitution of the monument" and the "reconstruction of the city." Behind the flooding of Florence or the burying of Rome, there was a project for the "reappropriation of the city." The erasure of the monument, with all its historical and cultural implications, represented for Superstudio an opportunity for the development of an active design process that could overcome the paralyzing condition that affected (and continues to affect) many Italian architects: if the extraordinary heritage of the historic city needed to be preserved categorically, how could an architect engage in a context in which everything had already been designed and nothing could be changed?

For Superstudio, only a radical gesture could liberate architecture from the constraints of the "organism that was born as the house of man, but had become his prison and final sepulcher."³¹ This tension could be overcome by imagining a new dimension with an "absurd historicity"—a dimension in which architects could emerge from the flood of history and once again play an active role in the city.³² Access to this utopic dimension was granted by the transcendence of architecture to a realm of absolute representation, one that embraced the critical value of the fantastic and the fictional. Reconstructing the world as a Piranesian *tabula rasa*—a "thing without form and empty"—Superstudio aimed to create the conditions for a new genesis in architecture.³³ The void was not the end of architecture, but rather a critical space in which multiple design processes could unfold: the design of the erasure, the design of

the routine of labour that produced the erasure, the design of the media that communicated the erasure, and so on. But beyond that, the act of hiding and subtracting generated a void in which the possibility of architecture could emerge once again.

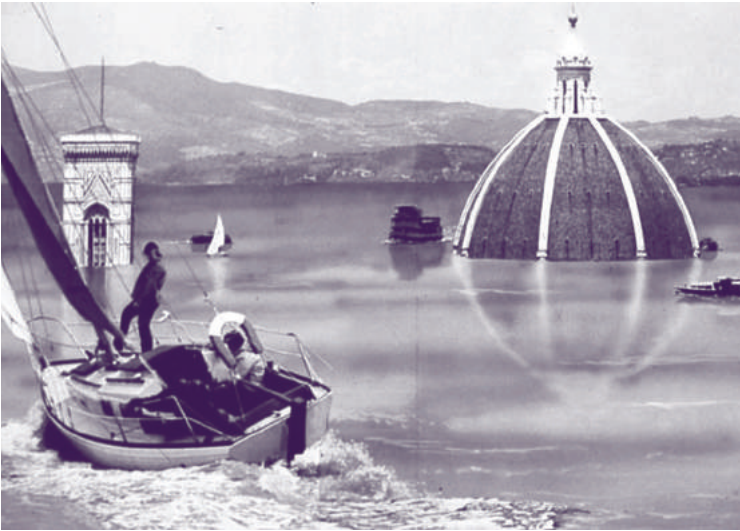

FIGURE 5
Superstudio: photomontage of the permanent flood of Florence.
IN Magazine (May-June 1972).

NOTES

†† I would like to thank Michael Osman and George Baker for taking the time to discuss this article with me.

¹ Superstudio, "Hidden Architecture," *Design Quarterly* 78/79 (1970): 54.

² Superstudio was founded in Florence in 1966 by Adolfo Natalini and Cristiano Toraldo di Francia. The group was later joined by Roberto Magris, Gian Piero Frassinelli, Alessandro Magris, and Alessandro Poli. Superstudio abandoned working as a collective in 1978. A detailed history of Superstudio's oeuvre is provided by Peter Lang and William Menking's *Superstudio: Life without Objects* (Milan: Skira, 2003) and by Roberto Gargiani and Beatrice Lampariello's *Superstudio* (Bari: Laterza, 2010).

³ Adolfo Natalini, Notebook, 18 July 1970 (Florence: Natalini Archive). Translated by Sebastiano Fabbrini.

⁴ Adolfo Natalini, Letter to *Domus*, 26 April 1971 (Florence: Natalini Archive). Translated by Sebastiano Fabbrini. In this letter, Natalini wrote: “The joyous death of architecture should not scare us: we have been preparing for this moment for a very long time, increasingly detaching ourselves from the physicality of building.”

⁵ Adolfo Natalini, Notebook, 18 July 1970 (Florence: Natalini Archive). Translated by Sebastiano Fabbrini.

⁶ Circa fifty years before *Hidden Architecture*, the issue of secrecy and concealment had been explored by Marcel Duchamp in *With Hidden Noise*. This 1916 assisted readymade was a ball of nautical twine placed between two brass plates. Before clamping the readymade shut with four long screws, Duchamp asked his friend and patron Arensberg to place an unknown object inside the ball of twine. The artist requested that Arensberg never tell him what the secret thing was: “I will never know whether it is a diamond or a coin.”

⁷ Adolfo Natalini, Notebook, 18 July 1970 (Florence: Natalini Archive). Translated by Sebastiano Fabbrini.

⁸ Superstudio, “Hidden Architecture,” *Design Quarterly* 78/79 (1970): 54.

⁹ In his notebook, Natalini wrote: “We must give this operation as much publicity as possible” (Florence: Natalini Archive). Translated by Sebastiano Fabbrini.

¹⁰ Adolfo Natalini, Notebook, 18 July 1970 (Florence: Natalini Archive). Translated by Sebastiano Fabbrini.

¹¹ Ibid.

¹² The idea of storing a series of miniature reproductions of a project into a box brings to mind Marcel Duchamp’s *Boîte-en-valise* (1935).

¹³ John Margolies, the editor of *Design Quarterly*, asked the contributors of this issue to curate the layout and the graphic design of their own articles, in an attempt to avoid any editorial interference in the authors’ presentations.

¹⁴ The photographs staged in Valleri’s workshop reveal Superstudio’s interest in manual tools—an interest that would lead to the creation of *Global Tools*, a nomadic program of design education organized by Superstudio and other Italian architects (Archizoom, 9999, and UFO, among others).

¹⁵ The use of legal documents in art projects is a recurrent trope in the history of modern art. Two examples that inspired Superstudio were Marcel Duchamp’s *Tzanck Check* (1919) and Yves Klein’s *Zone of Immaterial Pictorial Sensibility* (1959).

¹⁶ Adolfo Natalini, Notebook, 18 July 1970 (Florence: Natalini Archive). Translated by Sebastiano Fabbrini.

¹⁷ This “list of operations” has been mentioned in the recent monograph on Superstudio by Roberto Gargiani and Beatrice Lampariello (Bari: Laterza, 2010).

¹⁸ Adolfo Natalini, Notebook, 18 July 1970 (Florence: Natalini Archive). Translated by Sebastiano Fabbrini.

¹⁹ Peter Eisenman, “Notes on Conceptual Architecture: Towards a Definition,” *Design Quarterly* 78/79 (1970): 1-5.

- ²⁰ Superstudio's *Continuous Monument* was first exhibited at the Graz Biennale (1969) and then published in *Domus* 481 (1969), *Japan Interior Design* 140 (1970), and *Casabella* 358 (1971).
- ²¹ In 1966 a series of natural disasters took place in major Italian cities: the landslide of Agrigento, the flood of Florence, and the flood of Venice. In *Storia dell'Architettura Italiana: Il Secondo Novecento* (Milan: Electa, 1997), Francesco Dal Co argued that the history of Italian architecture of the *Secondo Novecento* started with the catastrophic events of 1966.
- ²² "How to Miss Cultural Sites," *Air Force Journal* (1944). As quoted by Michael Osman in the lecture "War: Fortification" (University of California, Los Angeles, 28 October 2014).
- ²³ *Carta Italiana del Restauro*, Report of the Italian Ministry of Public Education (Rome, 1972). Translated by Sebastiano Fabbrini.
- ²⁴ Aldo Rossi, *The Architecture of the City* (Cambridge: MIT Press, 1982). Alois Riegl, "The Modern Cult of Monuments," *Oppositions Reader* (New York: Princeton Press, 1998), 621-651.
- ²⁵ Both *Continuous Monument* and *Topographic Architecture* were deeply influenced by American land art. Projects such as Walter De Maria's *Walls in the Desert*, Robert Smithson's *Non Sites*, Michael Heizer's *Double Negative*, and Christo's *Wrapped Reichstag* made a significant impact on Superstudio's research. Germano Celant, a friend of Superstudio, was one of the key figures in introducing American environmental art to the Italian architectural debate.
- ²⁶ Adolfo Natalini, Notebook, 18 July 1970 (Florence: Natalini Archive). Translated by Sebastiano Fabbrini. Interestingly, the project was meant to be drawn on the topographic maps of the Italian Military Geographic Institute—the same maps provided to the allied fighter pilots during the bombing of Florence in World War II.
- ²⁷ Lucia Allais, "Disaster as Experiment: Superstudio's Radical Preservation," *Log* 22 (2011): 114-129.
- ²⁸ Superstudio, "Salvataggi di Centri Storici Italiani," *IN: Argomenti e Immagini di Design* (May - June 1972): 4-13. The theme of this issue of *IN* was *Destruction and Reappropriation of the City*. Superstudio's project focused on six Italian cities. In addition to the interventions mentioned here, the group proposed to incline all the buildings in Pisa, while straightening out the tower; to enclose Naples in a cylindrical shed painted with bright colours representing the panorama of the city circa 1800; and to drain Venice, paving the canals with glass blocks coloured to imitate the water. The project was introduced by a radical statement: "To salvage in order to destroy, to destroy in order to save yourself—in times of apocalypse, extremes meet and opposites equalize." Translated by Lucia Allais in *Log* 22.
- ²⁹ Superstudio, "Salvataggi di Centri Storici Italiani," *IN: Argomenti e Immagini di Design* (May - June 1972): 4-13. Translated by Lucia Allais in *Log* 22.
- ³⁰ *Ibid.*
- ³¹ *Ibid.*
- ³² Superstudio's projects were often based on the method of *demonstratio per absurdum*. The absurd was a critical model aimed at subverting the existing patterns of the architectural discourse. This concept was introduced in the manifesto of the *Continuous Monument*, published in *Domus* 481 (1969).
- ³³ Superstudio, "Storyboard of the Continuous Monument," *Casabella* 358 (1971): 20. At the beginning of the storyboard, Superstudio presented a drawing of an empty landscape, perhaps a desert. The caption of this image was a quote from the *Book of Genesis*: "In the beginning, God created the heavens and the earth, and the earth was without form and void."